

LITTLETON VILLAGE

Architectural Guidelines for Existing Residential Structures

October 2015

Revised November 2016

THE GOVERNING BOARD OF LITTLETON VILLAGE METROPOLITAN DISTRICT NO. 1 RESERVES THE RIGHT TO MODIFY THESE GUIDELINES AND THE POLICIES HEREIN AT ANY TIME IN ITS SOLE DISCRETION. PLEASE CONTACT THE MANAGEMENT COMPANY TO BE CERTAIN OF THE LATEST VERSION OF THIS DOCUMENT.

Welcome to Littleton Village

Welcome to Littleton Village, a mixed-use development near S. Broadway and E. Dry Creek Road in the City of Littleton. Littleton Village contains a variety of residential units as well as restaurant, retail and office spaces. This document pertains only to those single-family attached and detached homes (each a “Unit” or “Home”) subject to the Protective Covenants and Restrictions of Littleton Village (District No. 2) (“Covenants”), which property is referred to herein as the “Community”.

The developer of the Community previously promulgated the Littleton Village Architectural and Urban Design Standards and Guidelines (“Design Standards”). The Design Standards set forth design standards and guidelines for the construction of new structures and improvements within the Community, both residential and commercial. These Architectural Guidelines for Existing Residential Structures (“Residential Guidelines”) are intended to supplement the Design Standards for the purpose of providing guidance to homeowners within the Community who are planning exterior changes or alterations to their homes. This document pertains only to existing residential homes (each a “Unit or a “Home”) in the Community and does not apply to any proposed or existing commercial units or any residential property not subject to the Covenants (such as apartment buildings). Notwithstanding the intent of these Residential Guidelines to address exterior changes or additions to existing homes within Littleton Village, in the event any provision of these Residential Guidelines conflicts with any provision of the Design Standards, the Design Standards shall control.

Littleton Village contains several residential neighborhoods as shown on **Exhibit A**, each with its own distinct character. These Residential Guidelines may vary by neighborhood. A short summary of each neighborhood is provided below:

- **Neighborhood A.** Comprising those traditional single-family detached homes originally constructed by Richmond American Homes of Colorado, Inc. within Blocks 2-4, Littleton Village Replat No. 1.
- **Neighborhood B.** Comprising those higher-density single-family detached homes constructed by Richmond American Homes of Colorado, Inc. within Block 1, Littleton Village Replat No. 1.
- **Neighborhood C.** Comprising those single-family detached homes constructed by Century Communities within Blocks 7-14, Littleton Village Replat No. 2.

- **Neighborhood D.** Comprising those single-family attached townhomes constructed by Century Communities within Blocks 1-6, Littleton Village Replat No. 2.
- **Neighborhood E.** Comprising those single-family attached townhomes constructed by Century Communities within Lots 1-70, Littleton Village Replat No. 3.

Initially capitalized terms used herein shall have the same meaning as set forth in the Covenants unless otherwise provided herein.

Architectural Review

Article 2, Section 2.3 of the Protective Covenants and Restrictions of Littleton Village (District No. 2) (“Covenants”) states that no Improvements shall be constructed, erected, placed, altered, planted, applied, installed or modified upon any Unit unless complete plans and specifications have been first submitted to and approved in writing by the Architectural Control Committee (“ACC”).

Any improvement installed without ACC approval is subject to removal at the owner’s sole expense. The owner may also be subject to fines or other legal action.

<p><u>Please note:</u> All approvals must be in writing. On-site personnel, including a sales person or construction supervisor, do not have authority to approve ACC submissions.</p>

The ACC shall decide each request for approval within forty-five (45) days after the complete submission to the ACC of all plans, specifications and other materials and information which the ACC may require in conjunction with any application or request for architectural review. If the ACC fails to decide any application or request within forty-five (45) days after the complete submission of the plans, specifications, materials and other information with respect thereto, then such application or request for approval shall be deemed to have been denied by the ACC.

In reviewing any matter, neither the ACC, nor the Developer, shall be responsible for the safety, whether structural or otherwise, of any item(s) submitted for review, nor conformance with applicable building codes or other governmental laws or regulations, and any approval or conditional approval of an Improvement by the ACC, or the Declarant, shall not be deemed a representation that the same comply with any such codes or matters. Homeowners are solely responsible for securing any permits and applicable approvals from the City of Littleton. Further, the ACC will not make any investigation into title, ownership, easements, rights-of-way, or other rights appurtenant to property with respect to architectural requests and shall

not be liable for any disputes relating to the same. If your Home is subject to a side yard easement, it is your responsibility to bring this to the attention of the ACC, and you must ensure that any requested improvements will not violate any such side yard easement.

Submittal Procedures

1. All design review requests must be submitted through the District's Smartwebs portal.

How to Submit:

* Log in to your Smartwebs Resident Portal account at <https://littletonvillagemd2.com/guidelines/> and click on **Smartwebs Resident Portal**. If you have not yet registered, please create an account first.

* From your Owner Dashboard, select the ARC (Architectural Review) form under Quick Actions.

* Complete the form, upload required plans and supporting documents, and click Submit.

For detailed, step-by-step instructions including account registration, please review the SmartWebs Design Review Submission Guide at <https://littletonvillagemd2.com/guidelines/> and click **SmartWebs Design Review Submission Guide**.

2. Provide complete details and specifications, including but not limited to (as applicable):

- Plot plan showing the location of the Improvement(s).
- Size, species and quantities for any landscaping requests.
- Dimensions (i.e. height, width and length), description of materials, and color samples for any structures or equipment. Paint samples should be at least 8" x 10". In some cases, the ACC may require a sample of the material for its review. All samples will be provided at the applicant's sole expense,
- Applicant information including name, street address and phone number (and mailing address if different than that of the Unit).
- The ACC may require additional information depending on the nature of the request.

3. Plan ahead. The ACC strives to respond to requests quickly. However, the ACC normally meets once per month at irregular intervals, and may require up to forty-five (45) days after your complete submittal is received for a decision to be made.

4. A decision will be provided to you. A written decision could be:

- Approved
- Approved with conditions
- Pending further information
- Denied

Please note: If you do not receive a written decision within forty-five (45) days, your request is deemed denied.

ANY IMPROVEMENT INSTALLED WITHOUT APPROVAL IS SUBJECT TO REMOVAL AT THE HOMEOWNER'S SOLE EXPENSE. THE HOMEOWNER MAY ALSO BE SUBJECT TO FINES OR OTHER LEGAL ACTION.

Please note: The following guidelines are not all-inclusive. Questions should be directed to the management company, if any, or the ACC. Any requests not specifically addressed below will be reviewed by the ACC on a case-by-case basis.

Architectural Guidelines and Regulations

Accessory Structures

No structure of a temporary character, including a house trailer, shack, storage shed, or outbuilding, shall be placed or erected upon any Unit; provided, however, that during the actual construction, alteration, repair or remodeling of a structure or other Improvement, necessary temporary structures for storage of materials (and with respect to the Declarant, construction and sales trailers) may be erected, placed and maintained by the Person doing such work.

Notwithstanding the foregoing, Owners in Neighborhoods A and C may place certain types of permanent accessory structures in rear yards, such as gazebos, greenhouses or play equipment subject to prior ACC approval which will be evaluated on their individual merit, use, location on lot and appearance.

Owners in Neighborhood B, Neighborhood D, and Neighborhood E, may not place any accessory structures on the lot.

Additions and Remodeling

Approval is required for all additions, expansions, or remodeling which will alter the exterior of the residence. Submittals must include detailed plans, specifications, dimensions, and location. All plans for such improvements must match the overall theme of the residence.

The ACC may also require certification of any plans or drawings by a licensed engineer, as well as copies of building permit(s) upon their issuance.

Address Numbers

Address numbers may not exceed 6" in height. Submittal should specify location and materials.

Antennas/Satellite Dishes

Permitted Antennas

Antennas designed to receive direct broadcast satellite service or to receive or transmit fixed wireless signals via satellite which are one meter or less in diameter may be installed. Antennas designed to receive satellite signals or receive or transmit fixed wireless signals via satellite which are larger than one meter are prohibited.

Antennas which are one meter or less in diameter designed to receive video programming services via broadband radio service (wireless cable) or to receive or transmit fixed wireless signals other than via satellite may be installed. Such antennas larger than one meter are prohibited.

Antennas designed to receive televisions broadcast signals may be installed.

The above described antennas may be mounted on masts to reach the height needed to receive or transmit an acceptable quality signal. However, masts higher than 12 feet above the roofline are subject to approval as provided herein.

Acceptable Locations

Any antenna must be installed solely on the homeowner's individually-owned lot. No antenna shall encroach on any common areas or any other homeowner's lot. No antenna shall be placed in areas that obstruct access to or exit from any doorway or window of a residence, walkway, ingress or egress from an area, electrical service equipment, water shut-off valves or any other areas necessary for the safe operation of the Littleton Village community. The purpose of this requirement is to ensure the safe ingress or egress of the residents and Metro District personnel, and to ensure easy access to the Metro District' physical facilities.

If an acceptable quality signal can be received by installing the antenna wholly inside the residence and such installation does not unreasonably delay or increase the cost of installation, maintenance or use of the antenna, then outdoor installation is prohibited.

If an acceptable quality signal cannot be received from an indoor location, or such installation unreasonably delays or increases the cost of installation, maintenance or use

of the antenna, the antenna must be installed in the rear yard or in a side yard behind the front 1/3rd of the home.

If an acceptable quality signal cannot be received from the rear yard or the side yard, as described above, or such installation unreasonably delays or increases the cost of installation, maintenance or use of the antenna, the antenna shall be installed on the rear of the home or on the rear portion of the roof. If the antenna is installed on the rear of the roof, it shall be located as close to the chimney (if applicable) as possible and shall not extend above the roofline so as to be visible from the front of the building, provided an acceptable quality signal can be received and such installation does not unreasonably delay or increase the cost of installation, maintenance or use of the antenna.

If an acceptable quality signal cannot be received in any of the locations listed above, or if installation, maintenance or use of the antenna would be unreasonably delayed or the cost unreasonably increased in such locations, the antenna may be installed in another location on the owner's individually-owned lot that is the least visible from streets and other lots, in which an acceptable quality signal can be received and which does not unreasonably delay or increase the cost of installation, maintenance or use of the antenna.

Installation Regulations

Wiring or cabling shall be installed so as to be minimally visible and to blend into the material to which it is attached, provided that this requirement does not unreasonably delay or increase the cost of installation, maintenance or use of the antenna or does not void any manufacturers' warranties. If the antenna is installed on the front, rear or side façade of a structure, the penetration of the wire or cable from the exterior to the interior of the residence shall be made as close as possible to the location the antenna is attached to the structure and through existing penetrations for wire and cable, if available.

Mast Installation

Masts are prohibited except when necessary for reception of an acceptable quality signal, provided that such prohibition does not unreasonably delay or increase the cost of installation, maintenance or use of the antenna. Mast height may be no higher than absolutely necessary to receive an acceptable quality signal. Masts shall not encroach

upon another owner's lot or any common area. No antenna shall be placed in areas that obstruct access to or exit from any doorway or window of a residence, walkway, ingress or egress from an area, electrical service equipment, water shut-off valves or any other areas necessary for the safe operation of the Littleton Village community. The purpose of this requirement is to ensure the safe ingress or egress of the residents and Metro District personnel, and to ensure easy access to the Metro District' physical facilities.

Masts extending 12 feet or less beyond the roofline may be installed. Masts extending more than 12 feet beyond the roofline must be approved in writing by the ACC prior to installation due to safety concerns. An application for a mast in excess of 12 feet in height above the roofline must include a detailed description of the structure and anchorage of the antenna and the mast, as well as an explanation of the necessity for a mast higher than 12 feet. If this installation will pose a safety hazard, the ACC may prohibit such installation. Any such mast approved by the ACC must be installed by licensed and insured contractors to ensure proper and secure installation.

Artificial Turf

Approval is required prior to the installation of artificial turf. Artificial turf products will be considered on a case-by-case basis. Applicant shall include a product sample (minimum 10"x10") with the request, as well as installation specifications. Artificial turf will only be allowed in rear yards in Neighborhoods A and C, if at all.

Awnings and Overhangs

Approval is required prior to installation. Awnings or overhangs should be an integral part of the house or patio architecture. The color must be the same as, or generally recognized as a complementary to, the exterior of the residence. Awnings and overhangs will only be allowed in Neighborhood A, if at all.

Submittal must include a sample of the fabric/material to be used and state whether the awning or overhang is retractable or permanent.

Basketball Hoops

Garage-mounted and permanent free-standing basketball hoops are not allowed.

Portable basketball hoops are allowed and shall not require ACC approval. However, all portable basketball hoops shall be stored out of view from neighbors and the street when not in regular use.

Portable basketball hoops shall not be placed in alleys at any time.

Clotheslines and Drying Racks

No permanent clotheslines, clothes poles, drying racks or drying yards shall be constructed, installed, erected or maintained.

Notwithstanding the foregoing, with prior ACC approval, owners may install a retractable clothesline in the rear yard or in a side yard behind the front 1/3rd of the home as long as such installation does not impair or encroach into any side yard easement granted for the benefit of any other owner, and as long as the clothesline is screened from view from the ground level of other Units and from streets, open spaces or sidewalks abutting the Unit on which the clothesline is installed. Any such retractable clothesline shall be retracted when not in regular use.

Decks

Decks are subject to prior ACC approval, and may be installed in rear yards in Neighborhoods A and C only. Under no circumstances may any deck be attached to the residence on the neighboring Unit, and the installation of decks shall not impair or impede established drainage.

Decks must be redwood or a wood-look/textured material (e.g. Trex Deck). Wood decks shall be left their natural color, stained with a clear sealer, or stained to match fences. Painted decks are not permitted. Wood-look materials must be a color compatible with the color scheme of the home.

Decks must appear to be an integral part of the residence, and, in general, no part of the stairs or landings will be allowed to extend into the side property area beyond the back corners of the home. Deck railings must also match the stain of the deck, existing railings on the house or the general scheme within the Community. Deck skirting is not allowed on decks that are more than 2' above finished grade. No freestanding decks will be approved.

All decks must comply with setback restrictions.

Decorations, Permanent

Any permanent items such as yard statuary, benches, arbors, birdbaths, fountains, wall-mounted art, etc. are not allowed in the front yard of the property. Such items may be permitted in the rear yard subject to ACC approval.

Doors

Screen, storm and security doors shall be a neutral color (i.e. black, white, gray, bronze or consistent with color scheme of residence) and may not contain scrollwork or filigree. ACC approval is required.

Drainage

There shall be no interference with the established drainage pattern over any property within the Community except as approved in writing by the ACC. Approval shall not be granted unless provision is made for adequate alternate drainage. The "established drainage pattern" shall mean the drainage pattern that exists at the time the final grading of a Unit by the Developer or a Builder is completed.

Each Owner is required to contain mud, silt, or other debris on his/her own property. Owners are not allowed to increase or decrease historical flows of water onto adjacent property.

Driveways, Sidewalks and Patios

Pavers, flagstone or concrete are generally permitted materials, subject to ACC approval. Submittal package must specify which material and include a sample or color photo. Asphalt is not permitted. Under no circumstances may any patio be attached to the residence on the neighboring Unit, and the installation of patios shall not impair or impede established drainage.

Extending, expanding or widening of a driveway is not permitted.

Fences

Fences constructed by a Developer or a Builder may not be changed or relocated.

Homeowners in Neighborhood B, Neighborhood D and Neighborhood E shall not any install fences.

Homeowners in Neighborhood A and Neighborhood C may install fences according to the guidelines set forth below, or may replace fences as necessary over time, matching the design, style and color originally installed by the Developer or Builder.

Materials and Types

There are two types of fences at Littleton Village:

- (1) An open-rail style constructed from cedar and welded wire mesh, generally located between private lots and common areas; and
- (2) A privacy style constructed from cedar, generally located between lots (including wings), along E. Dry Creek Road, and those areas where lots side or back to commercial spaces. Pursuant to the Design Standards, privacy fences on any alley-loading lot must include a gate to access the alley. Additionally, the top 12 to 18 inches of all privacy fences which faces a public street must incorporate some change in articulation.

See fence details in **Exhibit B**. Note that open-rail fences should contain welded wire mesh and not chicken wire.

Stain and Treatment

Fences may be left untreated or treated with a clear sealer. Fences should not be stained or painted.

Garages

Each residence shall have a garage with the capacity for a minimum of two (2) cars. No garages shall exceed capacity for four (4) cars.

Garage doors shall be wood, hardboard, fiberglass or metal. All garage doors must be painted the same as, or generally recognized as a complementary to, the exterior of the residence. Garage doors should not remain open for an unreasonable amount of time.

See also Painting, exterior.

Gardens, Flower and Vegetable

The installation of new flower and vegetable beds or gardens requires ACC approval. All such beds or gardens may be installed in Neighborhoods A and C only. Vegetable beds or gardens are limited to back yards. Flower beds, vegetable gardens and other landscaping which requires regular watering shall not be planted within five feet of the foundation of the dwelling unit or any slab on the Unit. The mature height of garden plants shall not exceed 6'. All gardens shall be kept in a neat, weed-free condition. Railroad ties and chain link fences are not permitted for enclosing gardens.

Hot Tubs, Spas and Saunas

ACC approval is required for exterior hot tubs, spa equipment, saunas or jetted tubs (sometimes called Jacuzzis). All such equipment may be installed in Neighborhoods A and C only. Equipment must be installed in such a way that it is not immediately visible to and will not adversely impact neighbors by noise, drainage or other such problems. Equipment will only be permitted in back yards at ground level

HVAC

All heating, ventilation and air conditioning equipment shall be installed at ground level or completely contained within the structure. Townhomes may have AC condensers located within the front porch. Otherwise, ground-mounted equipment shall be located in the rear yard or in a side yard behind front 1/3rd of the home.

Roof-mounted or window-mounted HVAC equipment is not permitted.

Landscaping

Portions of the landscaping in Neighborhood B, Neighborhood D and Neighborhood E, both on the lots and within common areas, will be installed by the Developer or a Builder and will be maintained Littleton Village Metropolitan District No. 1.

Homeowners in these neighborhoods may not alter or interfere with any landscaping installed by the Developer or a Builder and maintained by the Littleton Village Metropolitan District No. 1.

Homeowners in Neighborhoods A and C shall install and maintain landscaping according to the guidelines set forth below.

Timing of Installation

Subject to obtaining prior ACC approval, homeowners in Neighborhoods A and C (other than Developer) shall install landscaping on any areas of the lot not landscaped by the Developer or the Builder by the earlier of the date required by the City or within one hundred eighty (180) days after the later to occur of the acquisition of such Unit by such Owner or the issuance by the City of a certificate of occupancy on the building residence constructed on the Unit if such acquisition or issuance occurs between April 1 and July 31; if such acquisition or issuance does not occur between such dates, then such landscaping shall be installed by such Owner by the following June 30.

Minimum Front Yard

- One (1) shade tree (evergreen or deciduous), 2" caliper or larger.
- Five (5) shrubs, 5-gallon size or larger.
- Automatic sprinkler system.
- Turf lawn minimum 50% coverage.

Note: The quantities above are in addition to the street trees located within the tree lawns.

Rear Yard

- One (1) shade tree (evergreen or deciduous), 2" caliper or larger.
- Automatic sprinkler system.
- Turf lawn minimum 25% coverage.

Materials

A list of recommended plant species is shown in **Exhibit C**. Homeowners are encouraged to select from this list. See also the list contained in the Design Standards.

Lights, Exterior

All exterior lighting requires ACC approval. All exterior lighting, including any security type fixture, must be directed downwards and the light “cone” created must be contained within the property boundaries to avoid a glare to neighboring properties.

Walkway lighting must be directed to the ground and shall not exceed 24” in height.

Painting, Exterior

ACC approval is not required when repainting a home using identical paint (manufacturer, colors and color scheme) as originally applied by the builder. However, any changes to the exterior paint will require ACC approval.

In general, the exterior colors of a home shall be primarily muted earth tones (e.g. gray, green, brown, beige, ivory, slate, etc.) with one or two accent colors applied to trim areas and architectural features/details.

Color samples must be at least 8”x10”, and marked clearly as to the areas in which they will be used. Submittal package must also include a current color picture of the home depicting the existing color scheme.

Pet Enclosures

Homeowners in Neighborhoods A and C may install certain pet enclosures subject to prior ACC approval.

The maximum size of a pet enclosure (i.e. a dog run) is three hundred (300) square feet.

Suggested methods of containment are:

- Open rail fence with heavy gauge wire.
- Privacy fence.
- “Invisible” below-ground electronic containment systems.

Chicken wire and chain link materials are not permitted.

Approval is required for all pet houses (i.e. dog houses). The maximum size of a pet house is sixteen (16) square feet. Pet houses must be located in the rear yard and must

not be visible above the fence line. Pet houses must be constructed with materials and colors which are compatible with exterior of the home.

Play Equipment

Homeowners in Neighborhoods A and C may install play equipment subject to prior ACC approval. This includes fort-style play structures, swing sets, climbing equipment, trampolines, etc. Submittal package must specify location and dimensions of play equipment, and include a product brochure or color photo.

All play equipment shall be located in the rear yard (or side yard as applicable for Neighborhood C) and must be a minimum of 6' from any property line. The maximum height of play equipment is twelve (12) feet from ground.

Sport courts will be evaluated on their individual merit, use, location on lot and appearance.

Retaining Walls

Approval is required. A single retaining wall shall not exceed thirty-six (36) inches in height (as measured at the exposed side) without an engineering plan.

Retaining walls should utilize a stone or brick material and will be reviewed on a case-by-case basis. Railroad ties and unfinished concrete masonry units are not permitted.

Roofing

Approval is required. In general, roofs shall be constructed with either asphalt shingle or concrete tile materials and utilize a product which is a minimum 40-year quality. Roofs must be a neutral color (e.g. brown, black or gray).

Partial replacement or patching of damaged roof sections must be completed with the same brand and color (or suitable replacement) such that the repaired section shall not be distinguishable.

In general, rooftop equipment is not permitted.

Siding and Exterior Materials (applicable to Neighborhoods A, B and C)

Approval is required for any changes to the siding or exterior materials of the home. In general, siding material should be wood or fiber cement (e.g. Hardie Plank). Aluminum, vinyl, and steel siding are not permitted.

The use of masonry (including stucco) is encouraged.

In general, all siding and exterior materials should utilize earth tone colors.

Signs

No advertising or signs of any character shall be erected, placed, permitted or maintained, except for a "For Sale," "Open House," "For Rent" or security signs of not more than five (5) square feet in the aggregate for all signs permitted by the foregoing. Such may be displayed without ACC approval.

Signs advertising garage sales are permitted without ACC approval, but may not be posted earlier than the night before the first day of the garage sale and must be removed immediately at the conclusion of the last day of the garage sale.

Additionally, political signs are permitted without prior ACC approval subject to the following:

- May be displayed no earlier than forty-five (45) days before election and seven (7) days after election.
- Shall be limited to one (1) sign per political office or ballot issue that is contested in a pending election.
- Each sign shall not exceed 36" x 48" in size.
- Each sign shall be displayed only on the owner's own lot.
- No political signs may be placed on any common areas owned and/or maintained by the District.
- Political signs are defined as those carrying a message intended to influence the outcome of an election, including supporting or opposing the election of a candidate, the recall of a public official, or the passage of a ballot issue.

Skylights (applicable to Neighborhoods A, B and C)

Skylights must be installed at the same pitch and angle of the existing roof. Bubble style skylights are not permitted.

Solar Panels and Solar Energy Devices

Solar panels will be reviewed on a case-by-case basis. In general, solar panels should follow the same pitch and angle of the existing roof so as to minimize visual impact to adjacent property owners.

Swimming Pools

Inflatable or lightweight wading pools and splash pools not to exceed twelve (12) feet in diameter may be located in rear yards in Neighborhoods A and C without ACC approval between the months of May and September.

All other swimming pools require approval prior to installation. Permanent above-ground pools are prohibited.

All appropriate permits must be obtained from the governing municipality and all safety requirements met.

Tree Lawns

Street trees must be a minimum 2 ½" caliper size planted approximately 40' on center. Tree Lawn shall match the existing turf planted by the Developer or Builder.

Water Features (applicable to Neighborhoods A, B and C)

Water features require prior ACC approval and will be evaluated on their individual merit, use, location on lot and appearance.

Weather Vanes (applicable to Neighborhoods A, B and C)

Weather vanes require prior ACC approval and will be evaluated on their individual merit and appearance.

Wind Energy Devices (applicable to Neighborhoods A, B and C)

Wind energy devices require prior ACC approval and will be evaluated on their individual merit, use, location on lot and appearance.

Windows

All windows shall be painted or stained wood, vinyl, composite or non-reflective metal framers and dividers. Reflective glass and reflective window tinting are not permitted.

All window coverings visible from outside the home shall be of a neutral color, such as white, tan or other muted earth tone.

Exhibit A: Map

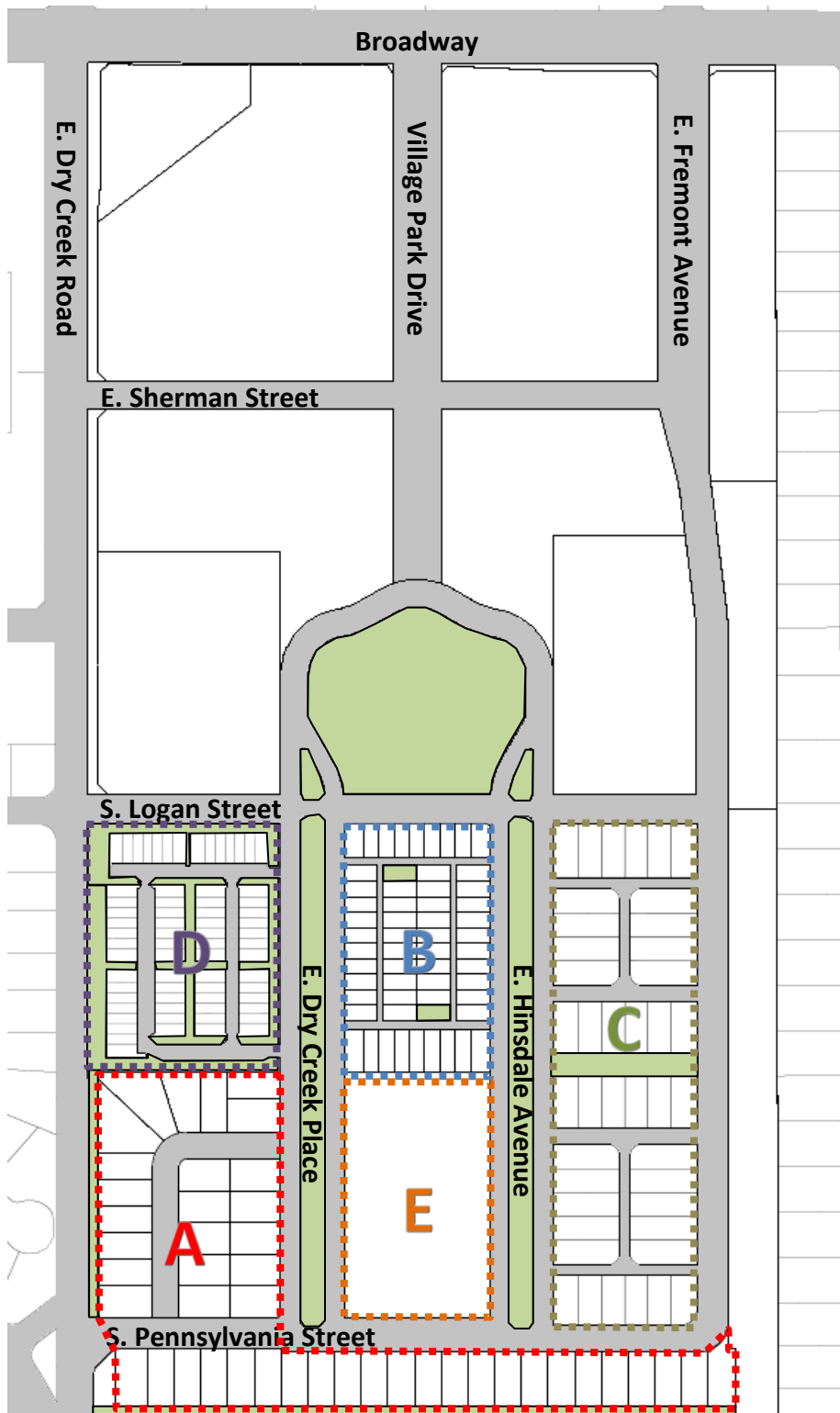

North →

Exhibit B: Fence Details

Open Rail:

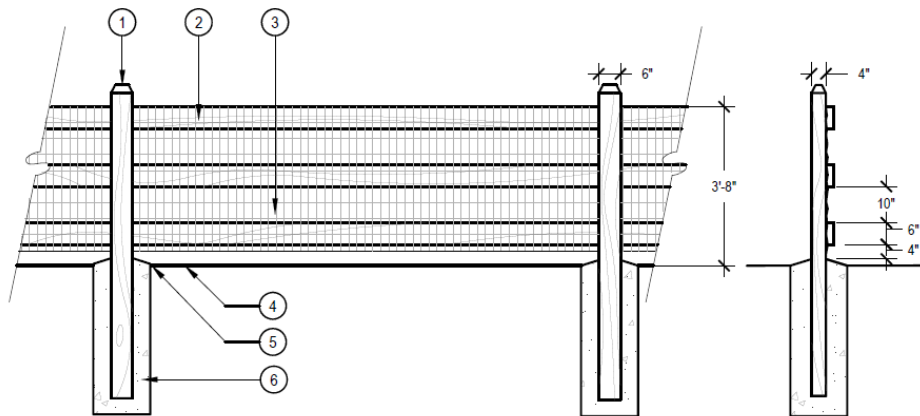

- (1) 1" chamfered top, 4" x 6" Cedar post.
- (2) 2" x 6" Cedar rails.
- (3) 2" x 4" welded wire mesh, 36" height between rails and post, stapled to rails 24" on center.
- (4) Finish grade.
- (5) Slope concrete away from post.

Privacy:

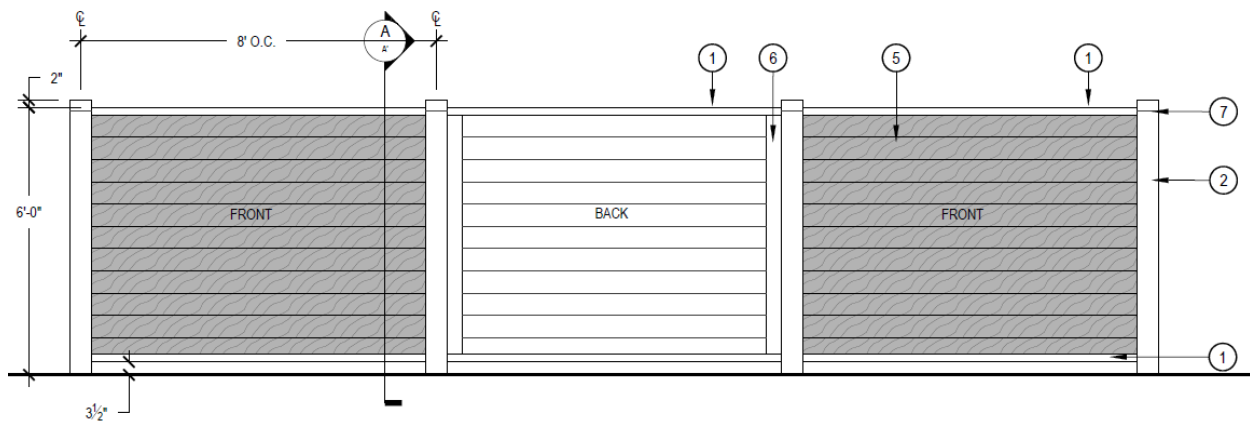

- (1) 2" x 4" Cedar rail, smooth surface.
- (2) 6" x 6" Cedar post, smooth surface.
- (3) 1" x 3" Cedar picket, smooth surface.
- (4) 1" x 6" Cedar picket, smooth surface.
- (5) 2" x 4" Cedar brace, smooth surface.
- (6) 1/2" x 1/2" reveal.

Exhibit C: Recommended Plant List

Deciduous Trees

Burr Oak
Accolade Elm
Kentucky Coffee Tree
Greenspire Linden
Sensation Maple
Shademaster Locust
Western Hackberry
Western Catalpa
American Linden
Texas Red Oak

Ornamental Trees

Autumn Brilliance Serviceberry
Chanticleer Pear
Golden Rain Tree
Radiant Crabapple
Spring Snow Crabapple
American Plum
Gambel Oak
Curl Leaf Mountain Mahogany

Evergreen Trees

Austrian Pine
Rocky Mountain Juniper

Deciduous Shrubs (2' to 5' spread)

Iroquois Beauty Dwarf Chokeberry
Pink Flower Carpet Rose
Miss Kim Lilac
Blue Mist Spirea

Deciduous Shrubs (2' to 5' spread)

Dwarf Burning Bush
Pawnee Buttes Sandcherry
Koreanspice Viburnum
Western Sandcherry
Buffaloberry
Chokecherry
Mountain Mahogany
Rocky Mountain Maple
Rabbitbrush
Russian Sage
Saskatoon Serviceberry
Common Purple Lilac
Silverberry

Ornamental Grasses

Blonde Ambition Grama Grass
Variegated Feather Reed Grass
Little Bunny Fountain Grass
Hardy Fountain Grass
Morning Light Maiden Grass
Purple Maiden Grass
Shenandoah Red Switch Grass

Perennials

Coronado Hyssop
Walker's Low Catmint
Stella de Oro Daylily
Ruby Star Coneflower